

SAGINAW CONTROL & ENGINEERING

SCE-84XR3EW18 Sheet 1 of 2

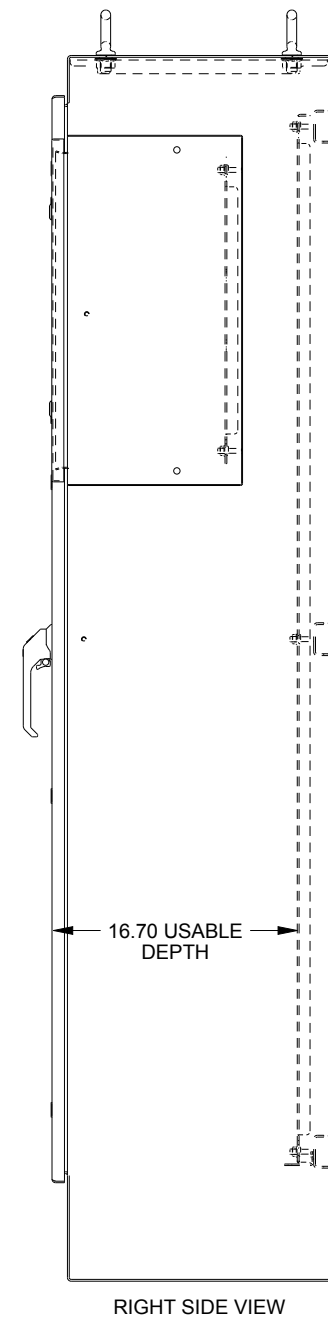
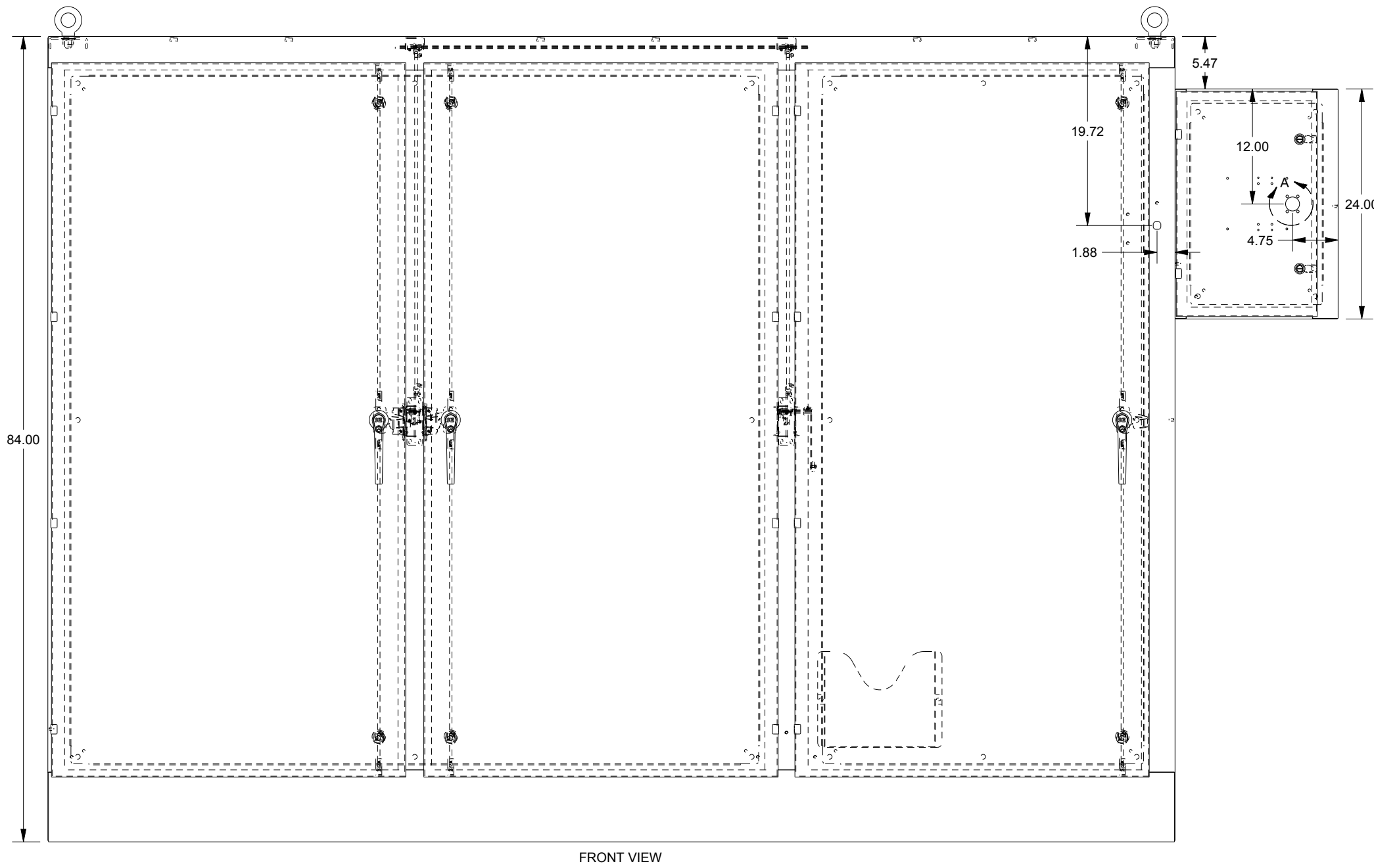
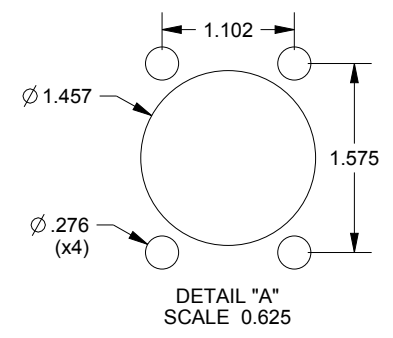
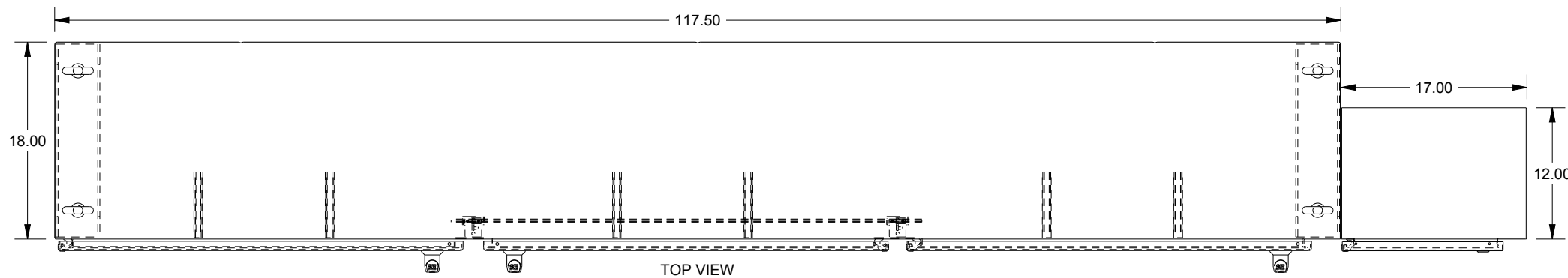

SAGINAW CONTROL & ENGINEERING

SCE-84XR3EW18 Sheet 2 of 2

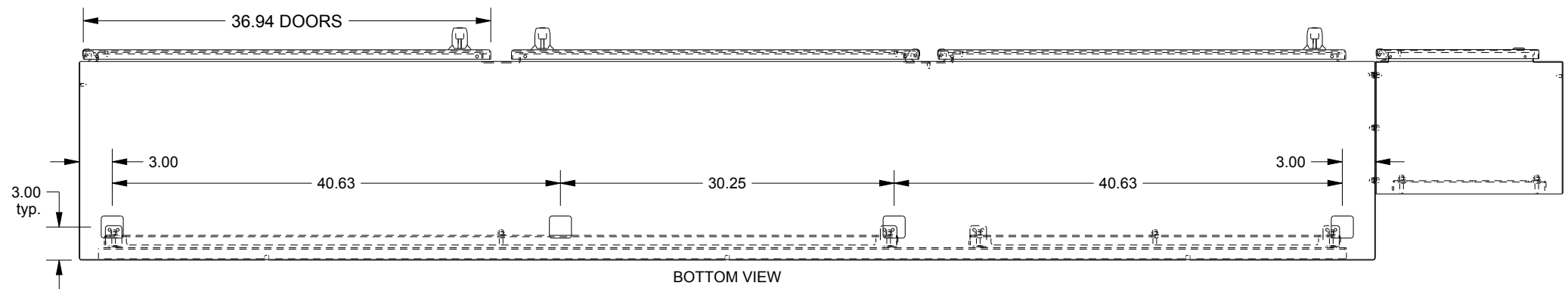
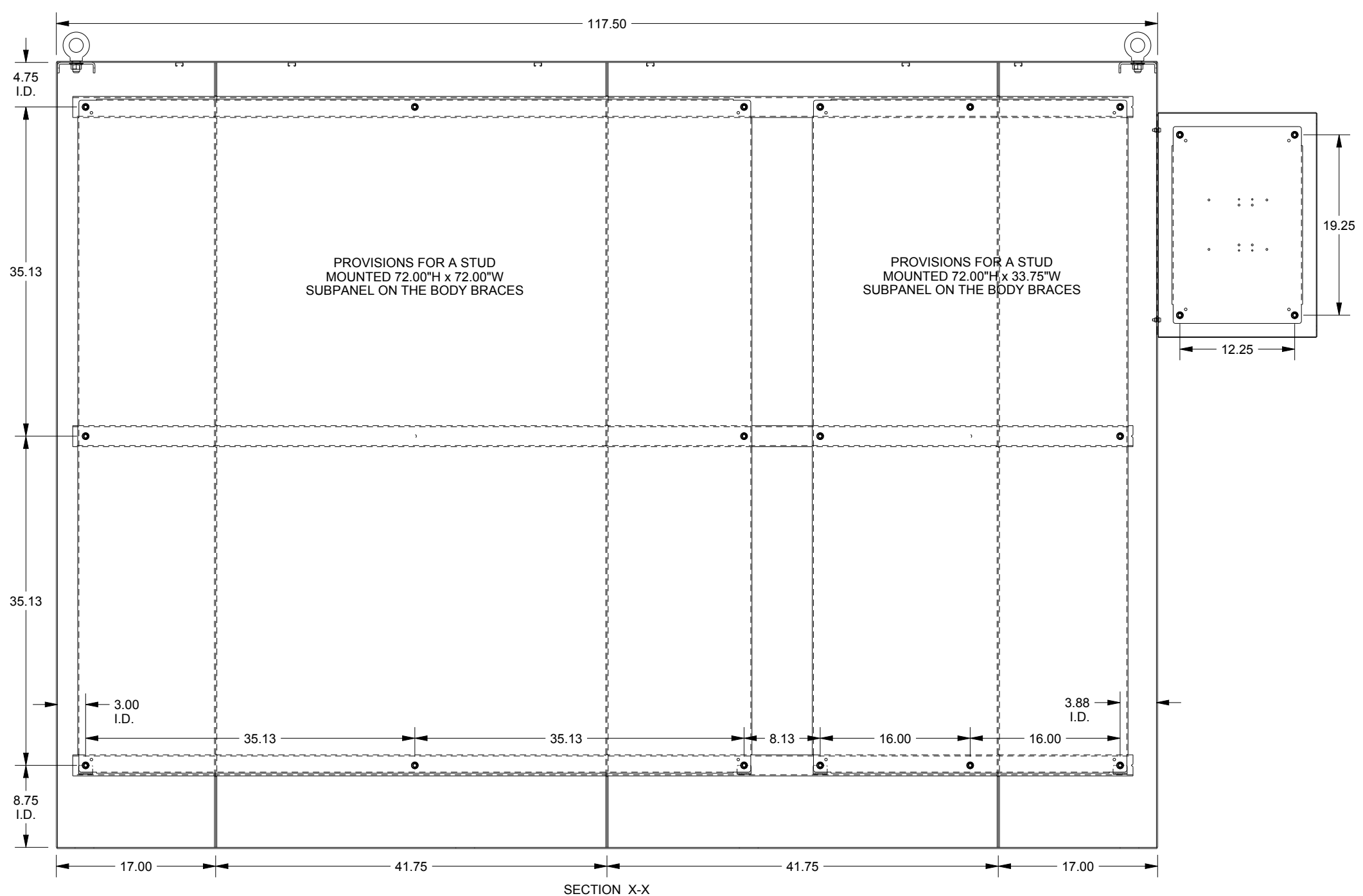
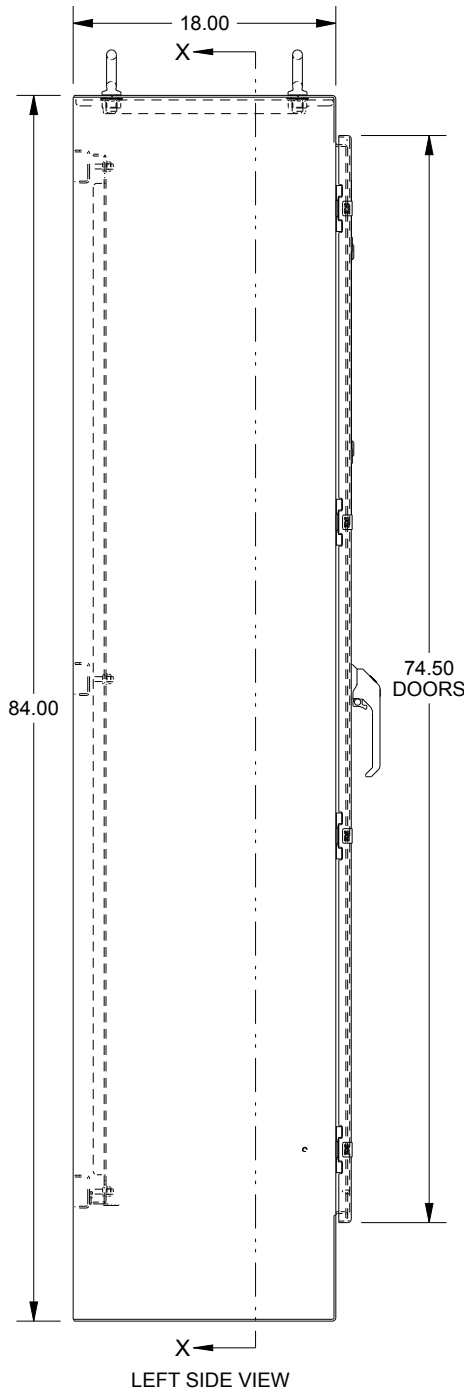

WASH SYSTEM 2" SQUARE DRAIN HOLES IN THE BOTTOM WITH UL APPROVED HOLE SEALS PROVIDED